

Phoenix Precast Products

Phoenix Precast Products

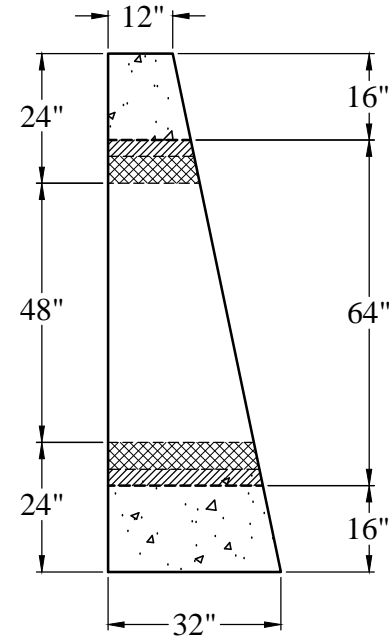
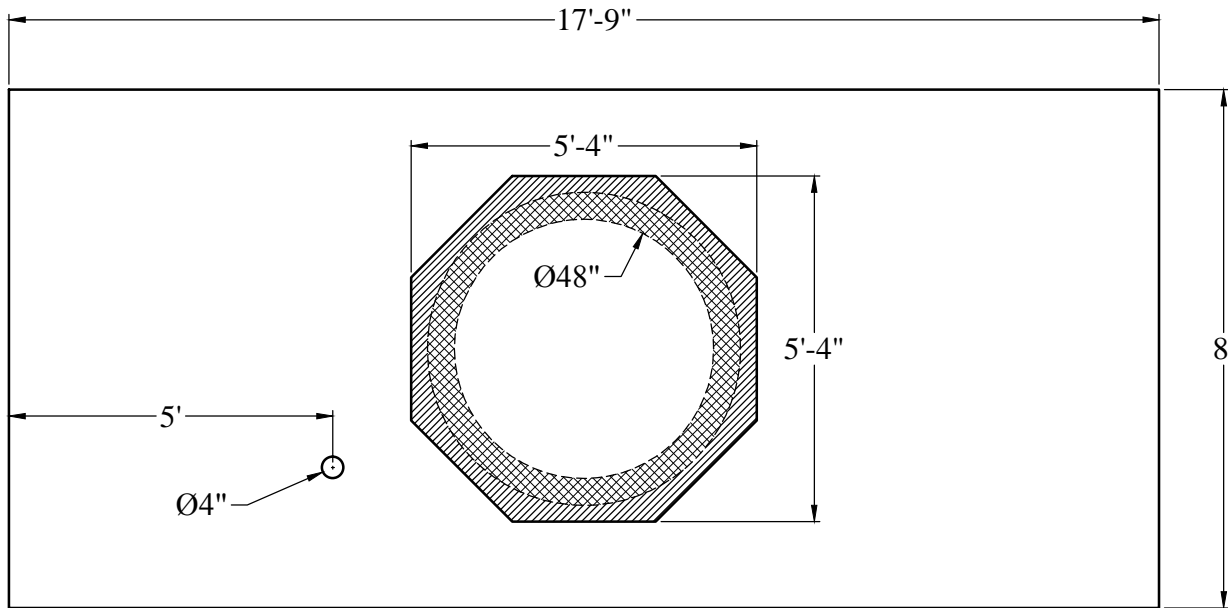

General Notes

1. Reinforcing Steel: ASTM-A615 Grade #60
2. Concrete: $f_c = 5,000$ PSI @ 28 Days Minimum
3. Est. Weight: 32,160 Lbs.

Phoenix
Precast
Products

N.H. DOT
48" RCP Headwall

P/N: HWSDOT-48RCP